



IMPORTANT:
Go to www.extron.com for the complete user guide, installation instructions, and specifications.

DMP 128 Plus • Setup Guide

This guide provides basic instructions for an experienced technician to install the DMP 128 Plus ProDSP™ Digital Matrix Processor. For more information, specifications, and the user guide, see the DMP 128 Plus product page on www.extron.com.

Disconnect Power and Mount the DMP 128 Plus

Disconnect power from the DMP 128 Plus and turn off all devices that will be connected to it. The DMP 128 Plus is housed in a full rack width, 8.5 inch deep, 1U high metal enclosure that can be rack mounted or placed on a table with the provided rubber feet. Select a suitable mounting location, then choose an appropriate mounting option. Mounting information can be found in the *DMP 128 Plus User Guide* on www.extron.com.

Make all external device connections before applying power.

Rear Panel Connections

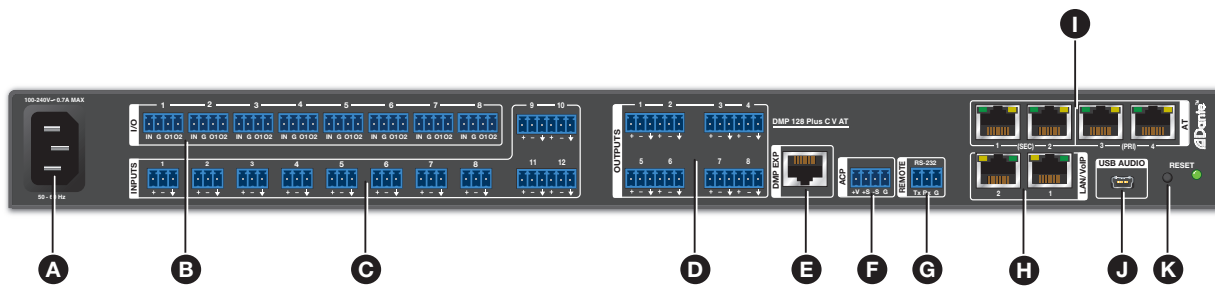
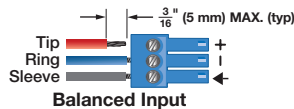

Figure 1. DMP 128 Plus Rear Panel

- A AC Power** — IEC power connector, 100–240 VAC, 50–60 Hz.
- B Digital I/O Ports** — Connect up to eight 4-pole 3.5 mm captive screw connectors. These configurable digital input and output ports are designed to connect to microphones with logic circuitry for mic mute and tally back functionality. Each port provides a common ground.
- C Mic/Line Inputs** — On inputs 1 through 8, use 3-pole 3.5 mm captive screw connectors to connect eight balanced or unbalanced microphone or mono line level sources (see 3-pole Audio Input Wiring below). Inputs 1 through 8 provide phantom power (all models) and AEC (C models only).
On inputs 9 through 12, use 6-pole 3.5 mm captive screw connectors to connect up to four balanced or unbalanced microphone or mono line level sources or two stereo sources (see 6-pole Audio Input Wiring below).



3-pole Audio INPUT Wiring



6-pole Audio INPUT Wiring

NOTES:

- Balanced or unbalanced stereo sources can be connected to the 6-pole inputs.
- When using the 5-pole CSR adapter, connect it so the far left plug is inserted into the far left jack of the 6-pole input (see the example to the right).

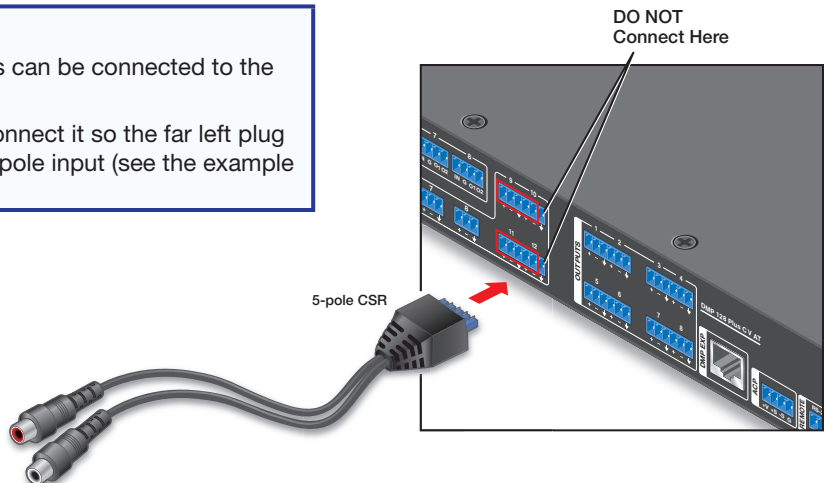

- D Line Outputs** — Use 6-pole 3.5 mm captive screw connectors to connect up to eight balanced or unbalanced mono line level devices or four stereo devices (see Audio Output Wiring below).

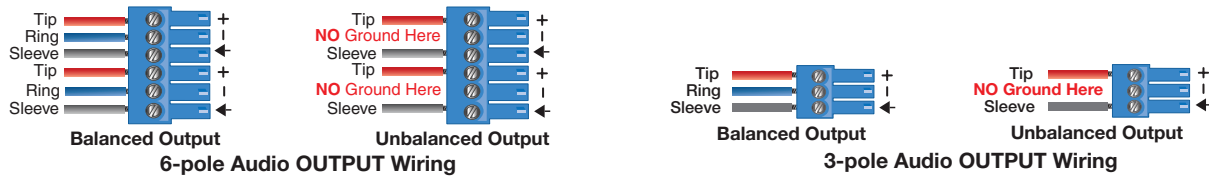

ATTENTION: For unbalanced audio outputs, connect the sleeves to the ground contact. **DO NOT** connect the sleeves to the negative (-) contacts.

ATTENTION : Pour l'audio asymétrique, connectez les manchons au contact au sol. Ne PAS connecter les manchons aux contacts négatifs (-).

- E EXP Port** — Connect an EXP-enabled device to this RJ-45 port for a digital audio connection using Extron proprietary protocol. Use the included one foot long shielded CAT 6 cable to connect two EXP-enabled devices to form a larger matrix system. The expansion bus supports 16 bidirectional channels of audio (see the *DMP 128 Plus User Guide* for EXP bus operation details).

- F ACP Panel Port** — Use a 4-pole 3.5 mm captive screw connector to connect an ACP control device for configuration via DSP Configurator (wiring shown to the right).



- G RS-232 Port** — Use a 3.5 mm 3-pole captive screw connector to connect the host RS-232 cable for bidirectional RS-232 ($\pm 5V$) serial control (wiring shown to the right). The default baud rate is 38400.

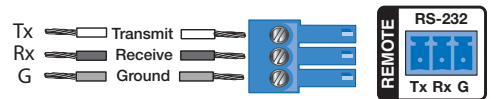

- H LAN Ports** — One RJ-45 port (non-V models) or two RJ-45 ports (V models) are available for control network traffic (all models) and VoIP network traffic (V models only). On DMP 128 Plus V models, the LAN/VoIP ports have multiple configuration options (refer to the *DMP 128 Plus User Guide* for configuration options). On V models, by default, both control and VoIP traffic are transported on LAN/VoIP 1.

Port	Default IP Address	Default Subnet Mask	Default Gateway	Default DHCP
LAN 1	192.168.254.254	255.255.255.0	0.0.0.0	OFF
LAN 2 (V models only)	192.168.1.254	255.255.255.0	0.0.0.0	OFF

- I AT Ports (AT models only)** — Four RJ-45 ports form a Gigabit switch that interfaces with the AT bus. The AT expansion bus uses Dante™ protocol for digital audio networking and allows DMP 128 Plus AT models to connect with other Dante-enabled devices to form a larger matrix (see the *DMP 128 Plus User Guide* for operation details).

NOTE: Dante Controller software is required to configure the AT expansion bus. Dante Controller is available at www.extron.com (see the *DMP 128 Plus User Guide* for instructions on installation and operation).

- J USB Audio Port** — Connect a Windows or Mac computer to this USB mini type B port to interface with the DMP 128 Plus as a 4x4 USB audio device (see the *DMP 128 Plus User Guide* for USB audio interfacing capabilities).

- K Reset Button and LED** — The reset button returns the DMP 128 Plus to different tiers of default states. When using the reset function, the LED blinks to signify the different reset modes. When not using the reset function, the LED operates as a power indicator and matches the front panel power LED (see the *Reset Modes* section of the *DMP 128 Plus User Guide* for more information on the different reset modes).

When all connections have been made, power up the input and output devices, then apply power to the DMP 128 Plus.

Front Panel Features

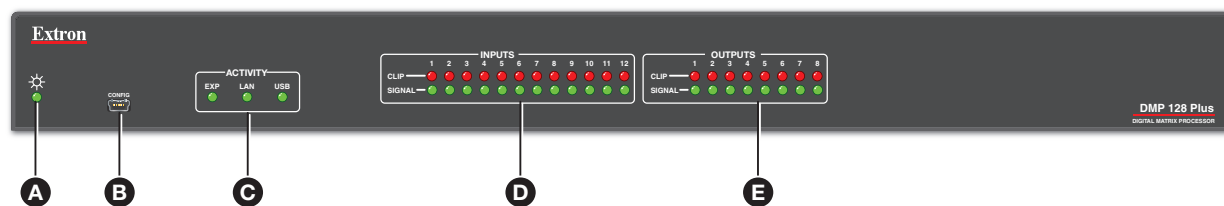

Figure 2. DMP 128 Plus Front Panel

- A Power LED** — Blinks during boot up and lights steadily when the DMP 128 Plus is operational.
- B USB Config Port** — One USB mini type B port is used for configuration. This port can also be used for firmware updates.

- C Activity Indicator LEDs** — These LEDs indicate activity or status on the rear panel EXP, LAN, and USB ports.
- D Input Indicator LEDs** — Stacked green and red LEDs display input signal presence and input signal clipping.
- E Output Indicator LEDs** — Stacked green and red LEDs display output signal presence and output signal clipping.

DSP Configurator Software Installation

There are no hardware controls for the DMP 128 Plus. All configuration and control is done using Extron DSP Configurator software. Install DSP Configurator on a PC running Microsoft® Windows®. For full computer requirements, see the DSP Configurator product page on www.extron.com.

Download DSP Configurator from the Extron Website:

- From the Extron home page (www.extron.com), click the **Download** tab to open the Download page.
- Under Software, on the left side of the page, select **DSP Configurator Software**. The DSP Configurator Software product page opens.
- Click the **Download** button and follow the on-screen instructions.

NOTE: An Extron Insider account is required to download DSP Configurator.

DMP 128 Plus Configuration

When power is connected to the DMP 128 Plus and the rest of the audio system, audio output can easily be tailored to any listening environment. When configuration is required, changes are made using DSP Configurator.

Configure the DMP 128 Plus:

- Ensure the control computer is connected to the LAN port (recommended), front panel USB Config port, or RS-232 port of the DMP 128 Plus. Full configuration that includes macros and ACP configuration requires a LAN connection.
- Start the DSP Configurator software. From the splash screen drop-down menu, select the DMP 128 Plus model corresponding to the model connected to the control computer. Click **OK** and the main workspace opens.
- The software starts in Emulate mode.
 - To create a configuration file offline and upload (push) that configuration to the DMP 128 Plus at a later time, remain in Emulate mode and save the configuration file.
 - To push a configuration to the DMP 128 Plus or pull the current configuration from the DMP 128 Plus, enter Live mode. When in Live mode, changes made in DSP Configurator affect the connected DMP 128 Plus immediately. To enter Live mode, click **Live** at the top of the DSP Configurator workspace, select **Tools > Connect to Device**, or press **<F6>** on the keyboard.

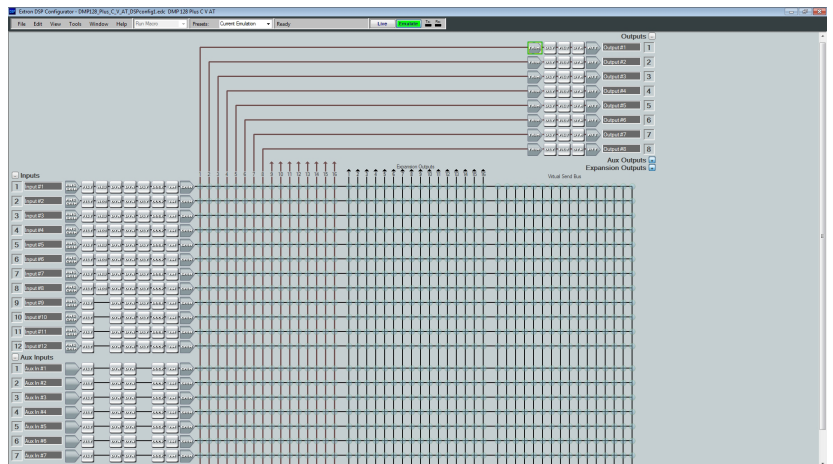

NOTE: When Live mode is selected, a connection dialog box appears. Select the desired connection type and follow the on-screen prompts (see the *DMP 128 Plus User Guide* for more information on connecting Live to a device).

The main workspace provides access to mix matrices, gain blocks, and DSP processors for configuring the DMP 128 Plus. It also provides a menu bar across the top with additional configuration tools. For more information about using DSP Configurator, see the *DSP Configurator Software* section of the *DMP 128 Plus User Guide* or the *DSP Configurator Help* file that can be accessed by selecting **Help > Contents** or pressing **<F1>** on the keyboard. Most dialog boxes within DSP Configurator contain a context sensitive **Help** button () in the top right corner. Click this button to open the help file topic for that specific dialog box.

Configure Dante Device Settings (AT Models Only):

Dante settings on DMP 128 Plus AT models can be configured from DSP Configurator. The Dante device can be named here, which aids in device identification in the Dante Controller software when there are multiple Dante devices on the audio network.

ATTENTION: It is essential that a Dante device be named before audio subscriptions with other devices are established. Existing subscriptions are removed when a device is renamed.

To configure Dante device settings:

1. Open DSP Configurator and connect Live to the DMP 128 Plus AT (see step 3b on the previous page).
2. Select **Tools>Device Settings**. The Device Settings dialog box opens.
3. From the tabs at the top of the Device Settings dialog box, select **Dante Device**.

- a. It may be necessary to use the right navigation arrow (▶) at the top right corner of the Device Settings dialog box to navigate to the **Dante Device** tab (see figure to the right).

4. In the **Device name** field, give the DMP 128 Plus AT a meaningful name (such as device model and location) so that it can be easily identified in Dante Controller.
5. Dante device network settings can also be configured from this dialog box. Use the radio buttons and text fields to choose **DHCP** (recommended) or **Static IP** and enter a static IP address configuration.

NOTE: The device name and IP configuration in the Dante Device tab only affect the Dante interface of the DMP 128 Plus AT. These settings do not affect the device name recognized in DSP Configurator or the IP address of the rear panel LAN port.

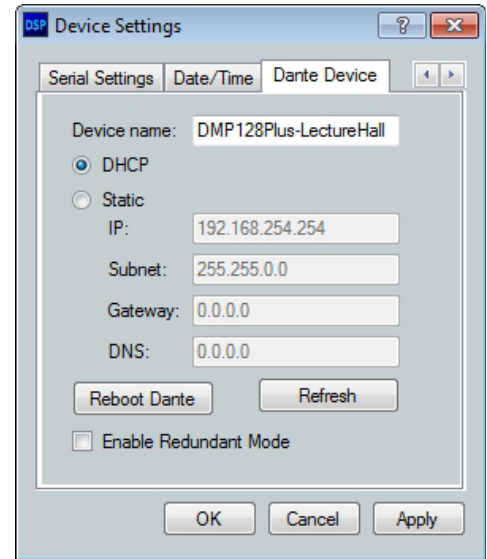

6. Select **Enable Redundant Mode** only if configuring the DMP 128 Plus AT for use on redundant networks. A separate set of redundancy network settings opens for configuration (see *Physical Dante Network Setup* in the *DMP 128 Plus User Guide* for more information on redundant configuration).
7. Click **Apply**.
8. Click **OK** to confirm changes and close the Device Settings dialog box.

For more information on configuring a DMP 128 Plus AT model in Dante Controller, refer to the *Dante Controller* section of the *DMP 128 Plus User Guide* (www.extron.com).

Extron Headquarters +800.633.9876 Inside USA/Canada Only	Extron Europe +800.3987.6673 Inside Europe Only	Extron Asia +65.6383.4400 +65.6383.4664 FAX	Extron Japan +81.3.3511.7655 +81.3.3511.7656 FAX	Extron China +86.21.3760.1568 +86.21.3760.1566 FAX	Extron Middle East +971.4.299.1800 +971.4.299.1880 FAX	Extron Australia +61.8.8113.6800 +61.8.8351.2511 FAX	Extron India 1800.3070.3777 (Inside India Only) +91.80.3055.3777 +91.80.3055.3737 FAX
Extron USA - West +1.714.491.1500 +1.714.491.1517 FAX	Extron USA - East +1.919.850.1000 +1.919.850.1001 FAX	+31.33.453.4040 +31.33.453.4050 FAX					